



## PSSu E F PS-P(-T)(-R)

**PILZ**  
THE SPIRIT OF SAFETY

- ▶ Decentralised system PSSuniversal I/O

This document is a translation of the original document.

All rights to this documentation are reserved by Pilz GmbH & Co. KG. Copies may be made for internal purposes. Suggestions and comments for improving this documentation will be gratefully received.

Source code from third-party manufacturers or open source software has been used for some components. The relevant licence information is available on the Internet on the Pilz homepage.

Pilz®, PIT®, PMI®, PNOZ®, Primo®, PSEN®, PSS®, PVIS®, SafetyBUS p®, SafetyEYE®, SafetyNET p®, the spirit of safety® are registered and protected trademarks of Pilz GmbH & Co. KG in some countries.



SD means Secure Digital

<b>Section 1</b>	<b>Introduction</b>	<b>5</b>	
	1.1	Validity of documentation	5
	1.1.1	Retaining the documentation	5
	1.2	Definition of symbols	5
<b>Section 2</b>	<b>Overview</b>	<b>7</b>	
	2.1	Module structure	7
	2.2	Module features	7
	2.3	Front view	8
<b>Section 3</b>	<b>Safety</b>	<b>10</b>	
	3.1	Intended use	10
	3.2	Safety regulations	11
	3.2.1	Use of qualified personnel	11
	3.2.2	Warranty and liability	11
	3.2.3	Disposal	11
<b>Section 4</b>	<b>Function description</b>	<b>12</b>	
	4.1	Block diagram	12
	4.2	Module features	12
	4.2.1	Supply voltage	12
	4.2.1.1	Current load capacity	12
	4.2.2	Integrated protection mechanisms	14
	4.3	Configuration	14
	4.3.1	Addresses in the process image	14
	4.3.2	FS error behaviour	14
<b>Section 5</b>	<b>Installation</b>	<b>15</b>	
	5.1	General installation guidelines	15
	5.1.1	Dimensions	15
	5.2	Installing the base module	16
	5.3	Inserting and removing an electronic module	17
	5.3.1	Inserting an electronic module	18
	5.3.2	Removing an electronic module	19
	5.3.3	Changing an electronic module during operation	19
<b>Section 6</b>	<b>Wiring</b>	<b>20</b>	
	6.1	General wiring guidelines	20
	6.1.1	Mechanical connection of the base modules	20
	6.2	Terminal configuration	22
	6.3	Connecting the module	24
<b>Section 7</b>	<b>Operation</b>	<b>25</b>	
	7.1	Messages	25
	7.2	Display elements	25
	7.2.1	Anzeigeelemente zur Moduldiagnose	25
	7.2.2	Display elements for the status of the periphery supply	26

---

<b>Section 8</b>	<b>Technical details</b>	<b>27</b>
<b>Section 9</b>	<b>Order reference</b>	<b>31</b>
	9.1 Product	31
	9.2 Accessories	31

---

# 1 Introduction

## 1.1 Validity of documentation

This documentation is valid for the product types PSSu E F PS-P, PSSu E F PS-P-T and PSSu E F PS-P-R. It is valid until new documentation is published.

The module PSSu E F PS-P-T is suitable for use where there are increased environmental requirements (see Technical Details).

This operating manual explains the function and operation, describes the installation and provides guidelines on how to connect the product.

### 1.1.1 Retaining the documentation

This documentation is intended for instruction and should be retained for future reference.

## 1.2 Definition of symbols

Information that is particularly important is identified as follows:



### **DANGER!**

This warning must be heeded! It warns of a hazardous situation that poses an immediate threat of serious injury and death and indicates preventive measures that can be taken.



### **WARNING!**

This warning must be heeded! It warns of a hazardous situation that could lead to serious injury and death and indicates preventive measures that can be taken.



### **CAUTION!**

This refers to a hazard that can lead to a less serious or minor injury plus material damage, and also provides information on preventive measures that can be taken.



### **NOTICE**

This describes a situation in which the product or devices could be damaged and also provides information on preventive measures that can be taken. It also highlights areas within the text that are of particular importance.

**INFORMATION**

This gives advice on applications and provides information on special features.

## 2 Overview

### 2.1 Module structure

A module consists of

- ▶ Electronic module and
- ▶ Base module with
  - Screw terminals or
  - Cage clamp terminals

The base modules are the carrier units for the electronic modules and are used to connect the field wiring. The electronic modules are inserted on to the base modules and determine the module's function.

Details of the base modules that can be used are available in the chapter entitled "Intended Use".

### 2.2 Module features

The product has the following features:

- ▶ Infeed for periphery supply
- ▶ Infeed for C-rail supply
- ▶ LEDs for:
  - Periphery supply
  - Module error
- ▶ Application range depends on the base module
- ▶ T-type:
  - PSSu E F PS-P-T: for increased environmental requirements
- ▶ R-type:
  - PSSu E F PS-P-R: for railway applications

## 2.3 Front view

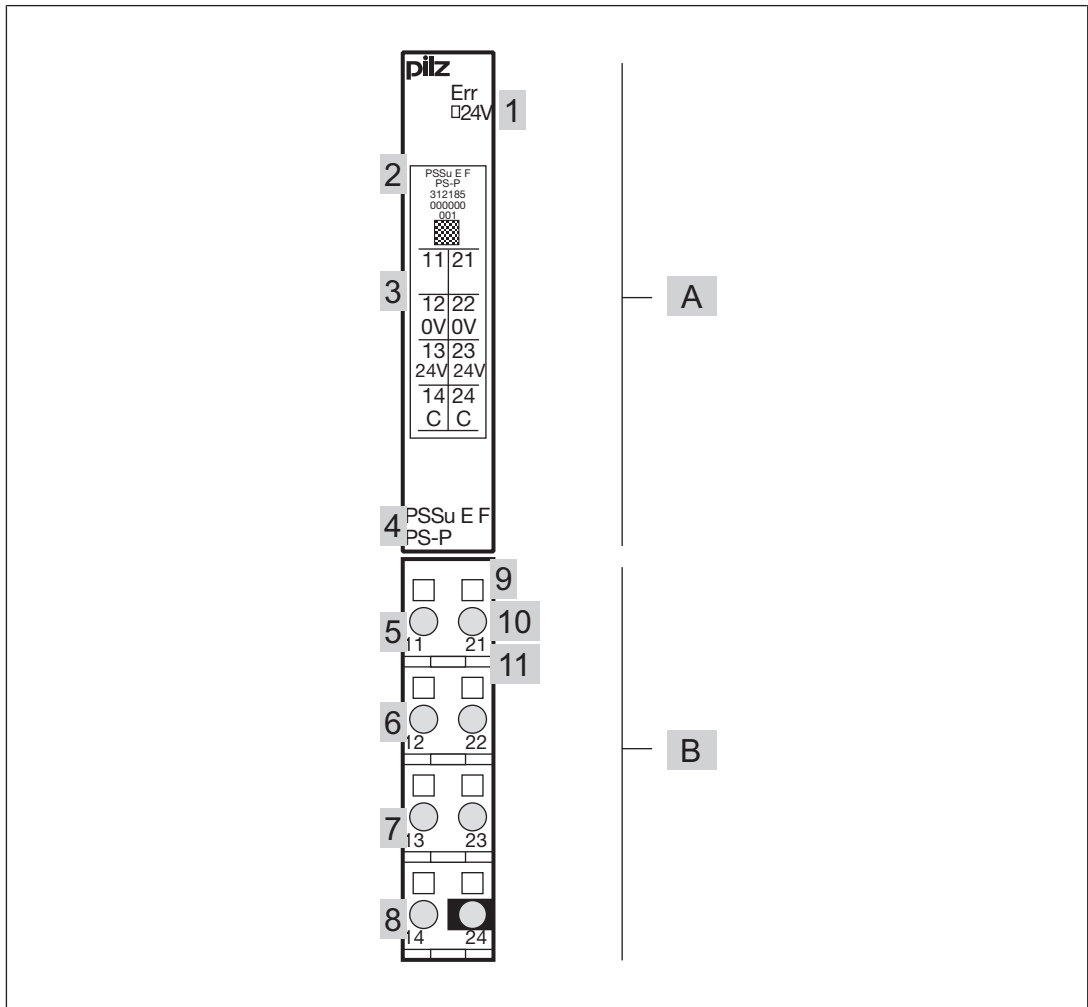

**Key:**

- ▶ A: Electronic module
- ▶ B: Base module
- ▶ 1: LED for module diagnostics
- ▶ 2: Labelling strip with:
  - Name of electronic module
  - Order number
  - Serial number
  - Hardware version number
  - 2D code
- ▶ 3: Labelling strip for the terminal configuration on the base module
- ▶ 4: Name of electronic module
- ▶ 5: Connection level 1
- ▶ 6: Connection level 2
- ▶ 7: Connection level 3
- ▶ 8: Connection level 4

- ▶ 9: Square mounting holes (connection levels 1, 2, 3 and 4)
  - With screw to loosen/tighten the screw terminal on base modules with screw terminals
  - With mechanism to operate the cage clamp on base modules with cage clamp terminals
- ▶ 10: Round connection holes (connection levels 1, 2, 3 and 4) for connecting the signal lines
- ▶ 11: Mounting slot for colour marker to label the connection level (connection levels 1, 2, 3 and 4)

## 3 Safety

### 3.1 Intended use

The module provides the supply for the periphery supply within the system.

The module be used as:

- ▶ Supply module to refresh the periphery supply
- ▶ Supply module to form supply groups

The module PSSu E F PS-P-T is suitable for use where there are increased environmental requirements (see Technical Details).

The module PSSu E F PS-P-R is suitable for use where there are increased environmental requirements demanded by railway applications (see Technical details).

Intended use includes making the electrical installation EMC-compliant. Please refer to the guidelines stated in the "PSSuniversal Installation Manual". The module is designed for use in an industrial environment. It is not suitable for use in a domestic environment, as this can lead to interference.

The following is deemed improper use in particular:

- ▶ Any component, technical or electrical modification to the module
- ▶ Use of the module outside the areas described in this manual
- ▶ Any use of the module that is not in accordance with the technical details.



#### INFORMATION

The module is supported by

- ▶ PSSuniversal Configurator and PSSuniversal Assistant from Version 1.4.0 (base type, T-type)
- ▶ PAS4000 from Version 1.1.1 (base type, T-type)
- ▶ PAS4000 from Version 1.5.0 (R-type)
  - We recommend that you always use the latest version (download from [www.pilz.com](http://www.pilz.com)).

The PSSu E F PS-P module may be used in conjunction with the following base modules:

- ▶ PSSu BS 1/8 S
- ▶ PSSu BS 1/8 C

The PSSu E F PS-P-T and PSSu E F PS-P-R modules may be used in conjunction with the following base modules:

- ▶ PSSu BS 1/8 S-T
- ▶ PSSu BS 1/8 C-T

## 3.2 Safety regulations

### 3.2.1 Use of qualified personnel

The products may only be assembled, installed, programmed, commissioned, operated, maintained and decommissioned by competent persons.

A competent person is a qualified and knowledgeable person who, because of their training, experience and current professional activity, has the specialist knowledge required. To be able to inspect, assess and operate devices, systems and machines, the person has to be informed of the state of the art and the applicable national, European and international laws, directives and standards.

It is the company's responsibility only to employ personnel who

- ▶ Are familiar with the basic regulations concerning health and safety / accident prevention,
- ▶ Have read and understood the information provided in this description under "Safety"
- ▶ Have a good knowledge of the generic and specialist standards applicable to the specific application.

### 3.2.2 Warranty and liability

All claims to warranty and liability will be rendered invalid if

- ▶ The product was used contrary to the purpose for which it is intended
- ▶ Damage can be attributed to not having followed the guidelines in the manual
- ▶ Operating personnel are not suitably qualified
- ▶ Any type of modification has been made (e.g. exchanging components on the PCB boards, soldering work etc.).

### 3.2.3 Disposal

- ▶ In safety-related applications, please comply with the mission time  $T_M$  in the safety-related characteristic data.
- ▶ When decommissioning, please comply with local regulations regarding the disposal of electronic devices (e.g. Electrical and Electronic Equipment Act).

## 4 Function description

### 4.1 Block diagram

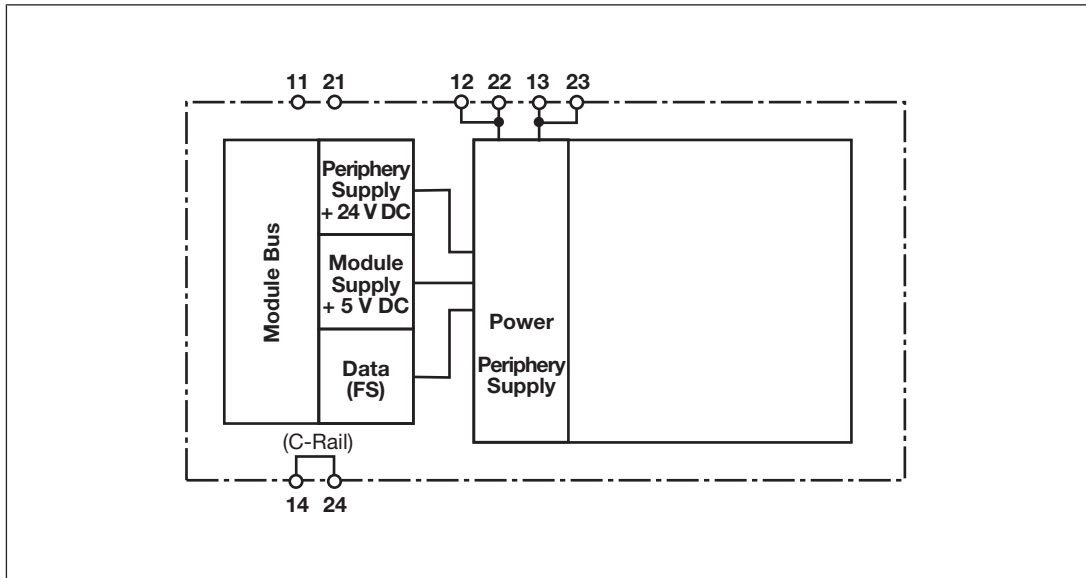

### 4.2 Module features

#### 4.2.1 Supply voltage

Module supply

- ▶ The module supply provides the module with voltage.

The product provides the periphery supply for the modules on the module bus:

- ▶ Refreshing the periphery supply: The relevant base module interrupts the connection to the incoming (left-hand) periphery supply and C-rail on the module bus.
- ▶ Supply to the module bus:
  - Periphery supply for subsequent modules (right-hand side)
  - C-rail supply for subsequent modules (right-hand side)
- ▶ The periphery supply does not automatically switch off if values exceed or drop below their limits. However, the "24V" LED will light and a message will be entered in the error stack or diagnostic log.

##### 4.2.1.1 Current load capacity

Ensure you comply with the current load capacity of the periphery supply (see "Technical Details"). If the current load is higher, an additional supply voltage module is required to refresh the periphery supply.

- ▶ Periphery supply

The current load is the total current consumption of the sensors, actuators and test pulses supplied via the input/output modules.

The periphery supply does not automatically switch off if values exceed or drop below their limits. However, the "24 V" LED will light and a message will be entered in the error stack or diagnostic log.

Please refer to the derating diagram.

▶ C-rail

If the current load is higher, the C-rail must use a different supply to prevent overload.

Please refer to the derating diagram.

PSSu E F PS-P: Derating diagram for periphery supply and C-rail: Temperature T dependent on load current I

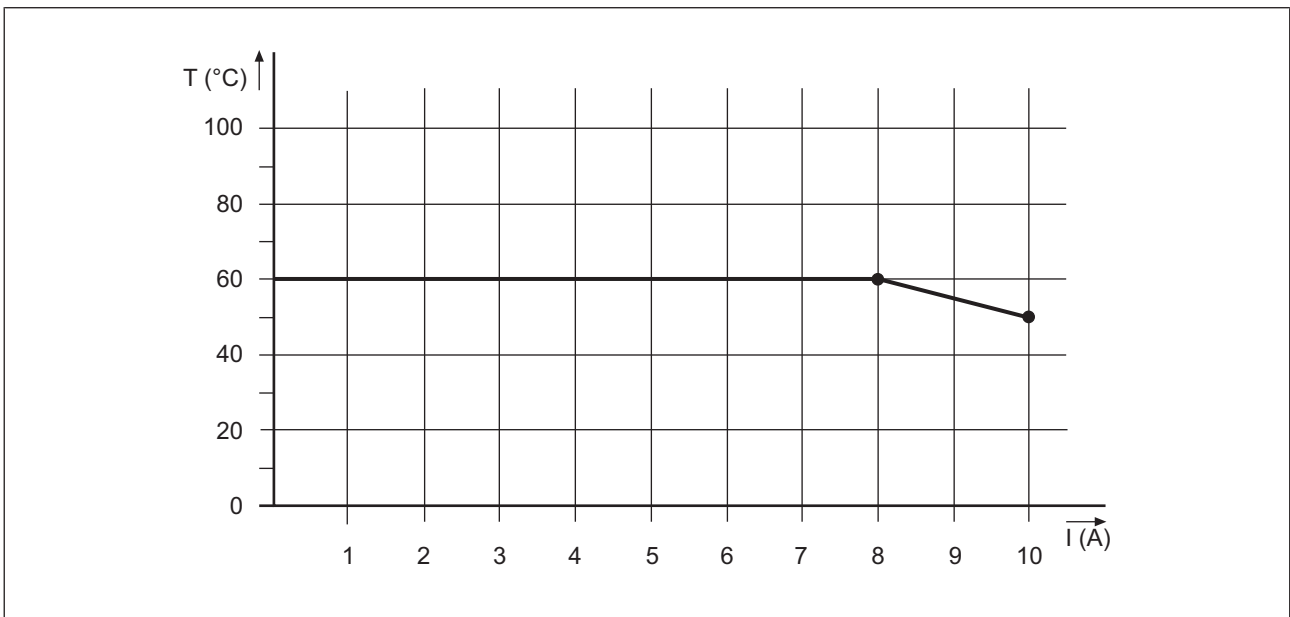

PSSu E F PS-P(-T)(-R): Derating diagram for periphery supply and C-rail: Temperature T dependent on load current I

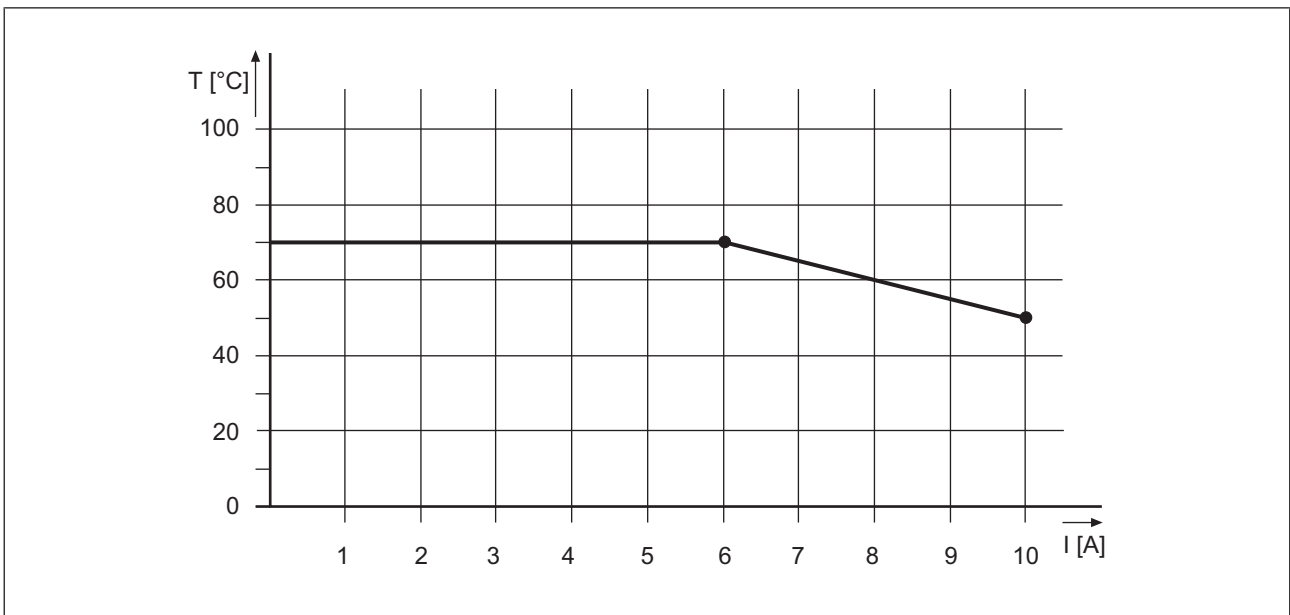

## 4.2.2 Integrated protection mechanisms

The module has the following protection mechanisms:

- ▶ Periphery supply
  - Voltage monitoring (exceeding upper/lower limit)

The module registers the following errors:

- ▶ Start-up error
- ▶ Configuration error
- ▶ FS communication error
- ▶ Bus termination error
- ▶ Temperature error: too warm
- ▶ Overvoltage error
- ▶ Undervoltage error
- ▶ Error in the overvoltage protection diodes

## 4.3 Configuration

The module does not have to be configured.

### 4.3.1 Addresses in the process image

The module does not occupy any addresses in the process image.

### 4.3.2 FS error behaviour

In the case of a safety-related error on an FS output, all FS outputs in the affected I/O-Group (SafetyBUS p) are shut down.

In the case of a safety-related error on an FS input, the process image of all FS inputs in the affected I/O-Group (SafetyBUS p) is set to zero.

The I/O-Group switches to a STOP condition. An error telegram is then triggered on Safety-BUS p and the error is entered in the PSSuniversal error stack.

## 5 Installation

### 5.1 General installation guidelines

Please refer also to the PSSuniversal Installation Manual.



**NOTICE**

Damage due to electrostatic discharge!

Electrostatic discharge can damage components. Ensure against discharge before touching the product, e.g. by touching an earthed, conductive surface or by wearing an earthed armband.

#### 5.1.1 Dimensions

Base modules with four connection levels:

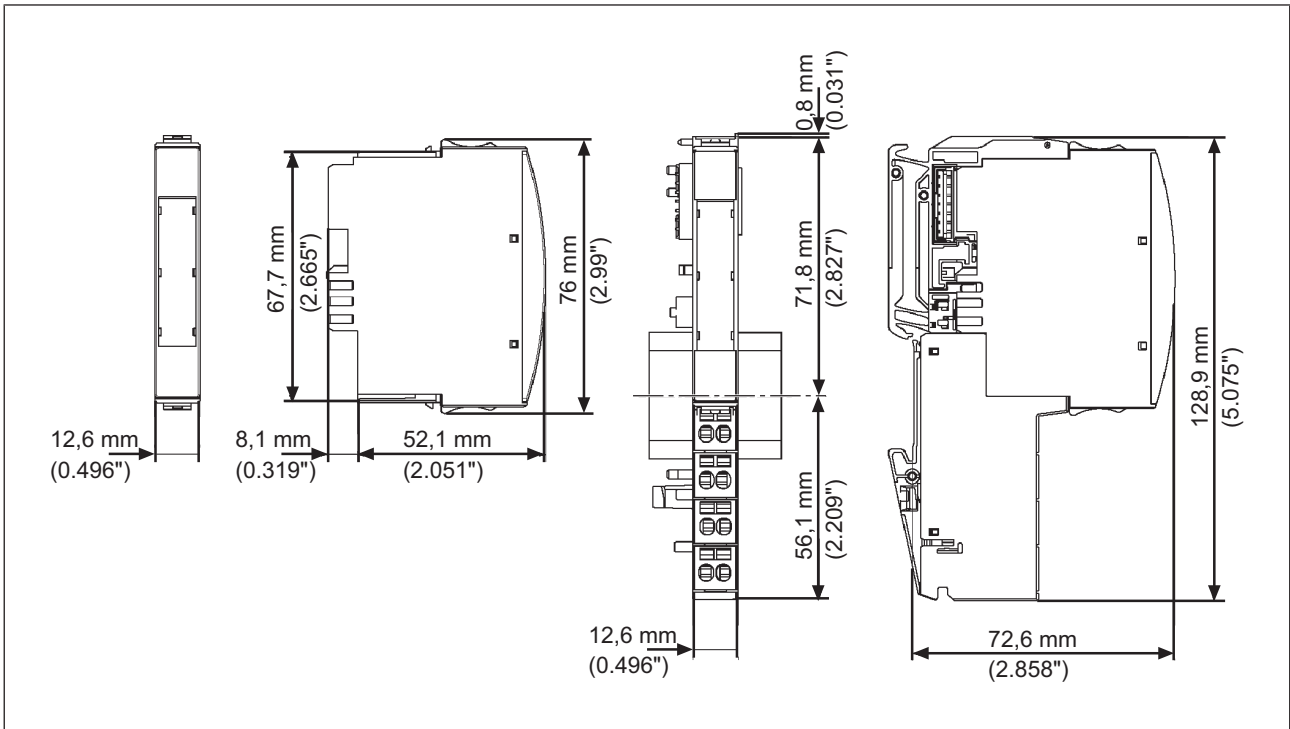

## 5.2 Installing the base module

Prerequisite:

- ▶ The head module must be installed.
- ▶ If the head module does not have an integrated power supply, a supply voltage module must be installed to the right of the head module.

Please note:

- ▶ For mechanical reasons it is not possible to mix base modules with screw terminals and base modules with cage clamp terminals.
- ▶ All contacts should be protected from contamination.
- ▶ The mechanics of the base modules are designed for 50 plug in/out cycles.

Procedure:

- ▶ We recommend that you wire up the base modules before inserting the electronic modules.
- ▶ Slot the groove on the base module on to the mounting rail from below [1].
- ▶ Push the base module back [2] until you hear it lock into position.
- ▶ On the mounting rail, slide the base module to the left until you hear the two lateral mounting hooks on the adjacent module lock into position [3].

Schematic representation:

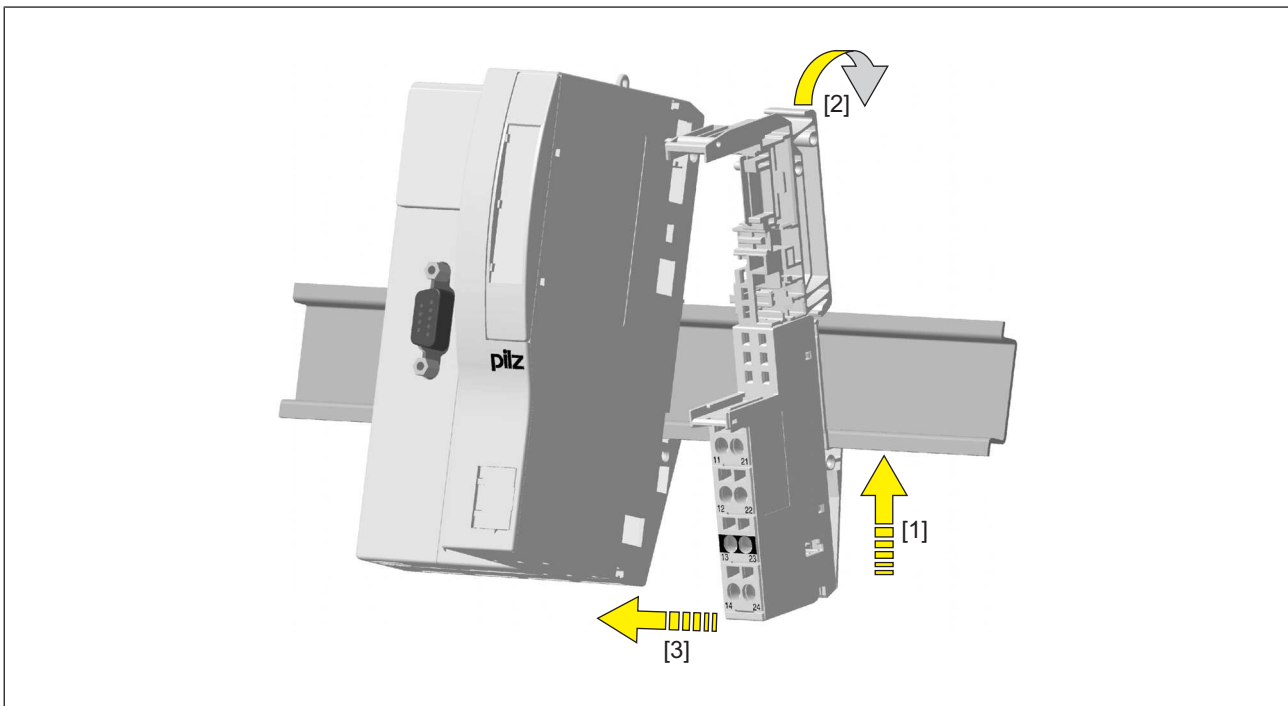

## 5.3 Inserting and removing an electronic module

Please note:

- ▶ Only insert on to base modules that are already installed.
- ▶ Preferably these base modules should be ready wired.
- ▶ Electronic modules with outputs may only be inserted and removed when the load is switched off. Unforeseeable error reactions may be triggered if modules are inserted and removed under load.
- ▶ When an electronic module is plugged into a base module for the first time, one part of the coding element remains on the electronic module, while its counterpart is fixed on to the base module. This is how the base module is coded.
- ▶ The mechanics of the electronic modules are designed for 50 plug in/out cycles.

### 5.3.1 Inserting an electronic module

Procedure:

- ▶ The electronic module must audibly lock into position [1].
- ▶ Mark the electronic module using the labelling strips [2].

Schematic representation:

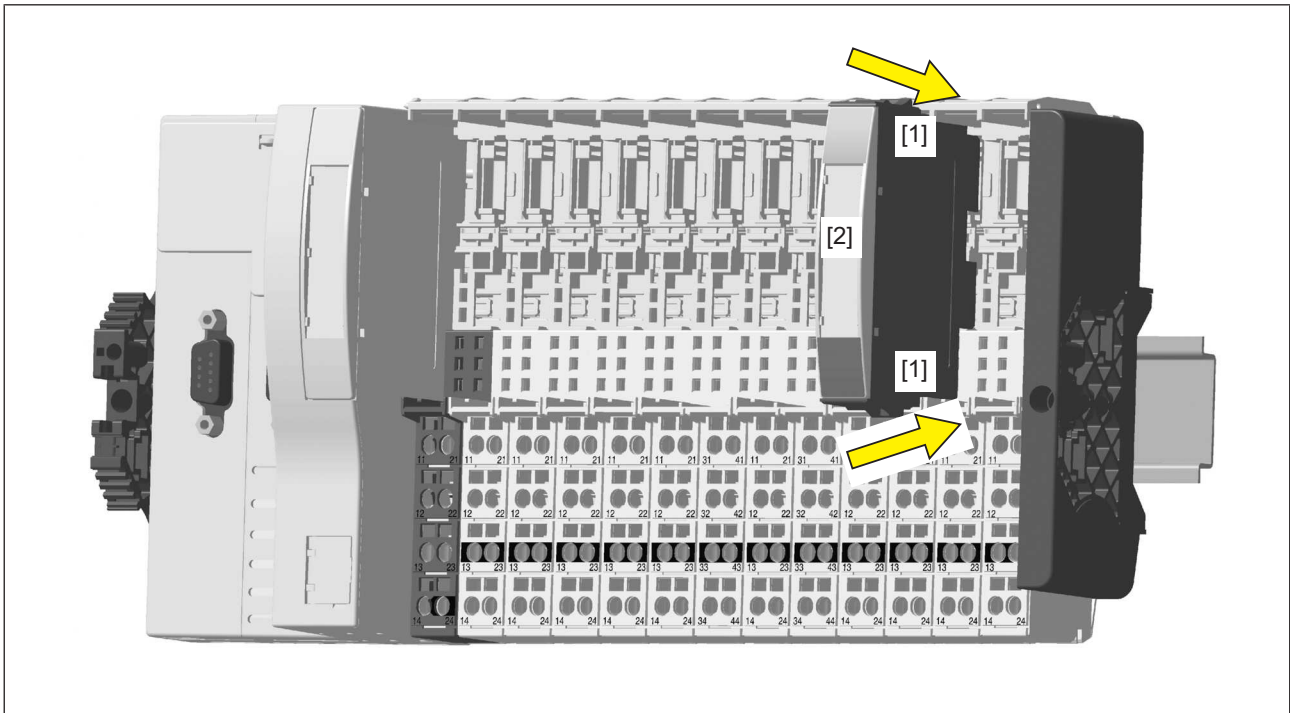

### 5.3.2 Removing an electronic module

Procedure:

- ▶ Press the locking mechanisms [1] together simultaneously.
- ▶ Pull out the electronic module [2].

Schematic representation:

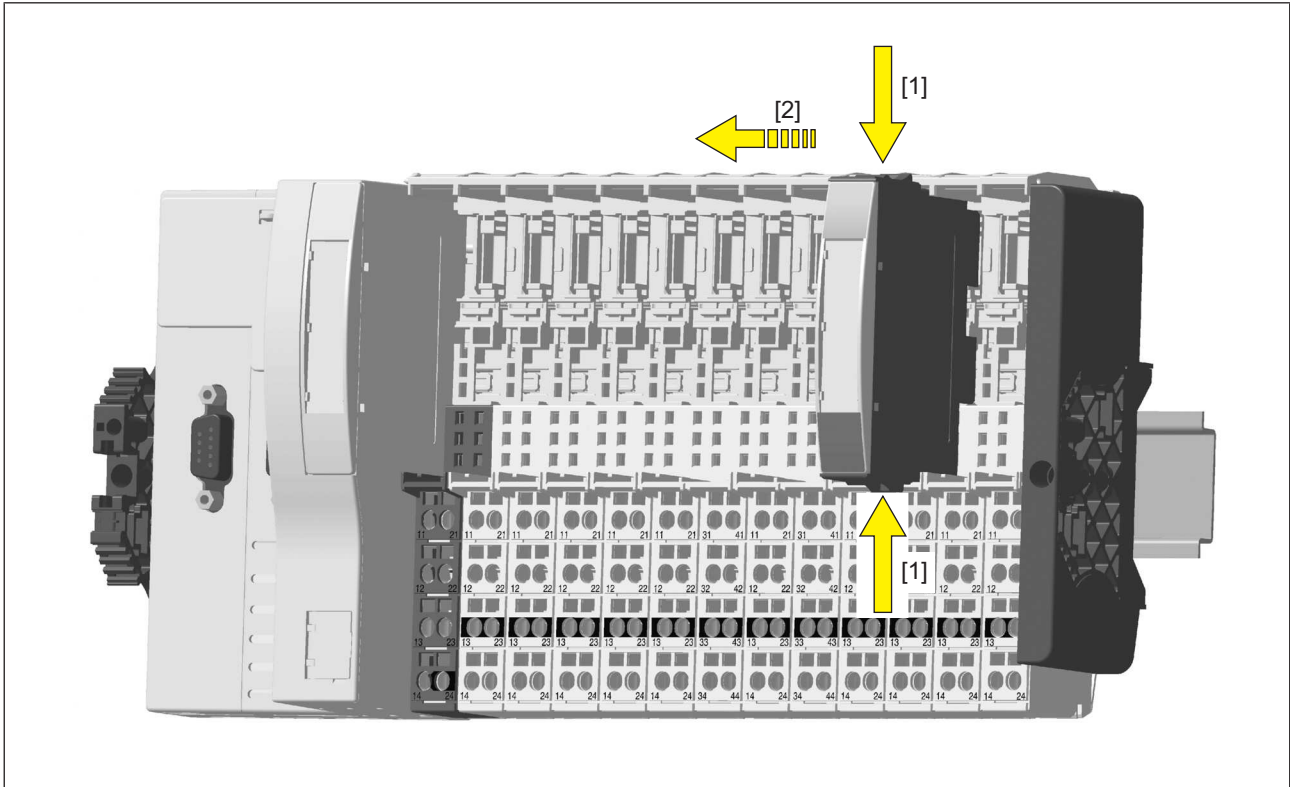

### 5.3.3 Changing an electronic module during operation

It is possible to change an electronic module during operation. The configuration data is retained when a module is changed.

Effects:

- ▶ System environment A:
  - In the event of a potential FS communication error, the FS section of the PSSu system and all relevant I/O-Groups (SafetyBUS p) switch to a STOP condition.
- ▶ System environment B:
  - All FS hardware outputs on the PSSu system switch to a safe condition.
  - The substitute values are used for the modules' FS outputs, with Valid Bits = FALSE.



#### CAUTION!

Sparking can cause interference and errors!

Only change the module when the load is switched off!

## 6 Wiring

### 6.1 General wiring guidelines

Please note:

- ▶ The requirements of the supply voltages can be found in the chapter entitled "Technical Details".
- ▶ Protective separation must be ensured for the external power supplies that generate the supply voltages. Failure to do so could result in electric shock.
- ▶ The external power supplies must comply with the current applicable standard EN 60950-1, EN 61140, EN 50178 or EN 61558-1.
- ▶ The maximum current load for the periphery supply on the module bus is 10 A. Please refer to the derating diagram in the chapter entitled "Function Description".
- ▶ Earth the 0 V supply on the periphery supply or monitor each supply group for earth faults.
- ▶ The connection of the 0 V supply to the central earth bar or earth fault monitor must be in accordance with relevant national regulations (e.g. EN 60204-1, NFPA 79:17-7, NEC: Article 250).
- ▶ Details of the minimum range for conductor cross sections on connection terminals can be found in the section entitled "Technical Details".
- ▶ Use copper wiring.

#### 6.1.1 Mechanical connection of the base modules

Procedure:

- ▶ Use a flat blade screwdriver (DIN 5264-A)!

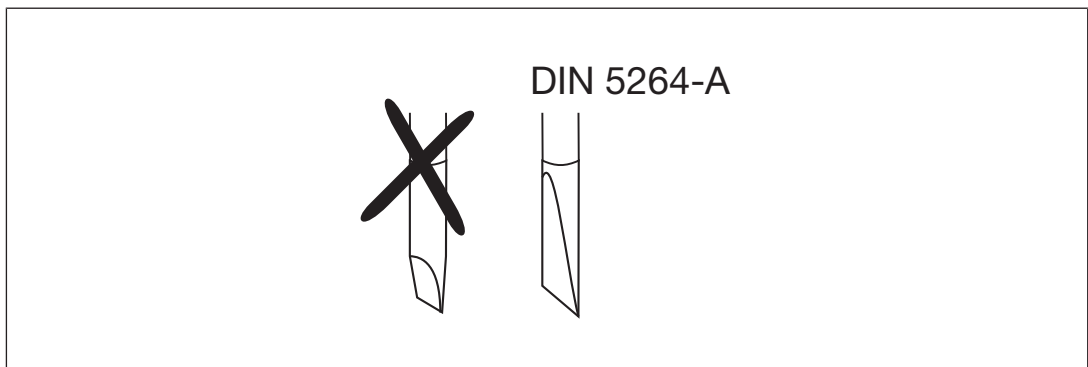

- ▶ Strip the wire back 8 mm.
- ▶ If necessary, label the connection level with a colour marker [3].
- ▶ Base module with screw terminals:
  - Use a screwdriver to loosen the screw on the screw terminal [1]
  - Insert the stripped cable into the round fixing hole [2], as far as it will go.
  - Tighten up the screw on the screw terminal.
  - Check that the cable is firmly seated.

- ▶ Base module with cage clamp terminals:
  - Insert the screwdriver [4] into the square hole [1].
  - Insert the stripped cable into the round fixing hole [2], as far as it will go [5].
  - Pull out the screwdriver [6].
  - Check that the cable is firmly seated.

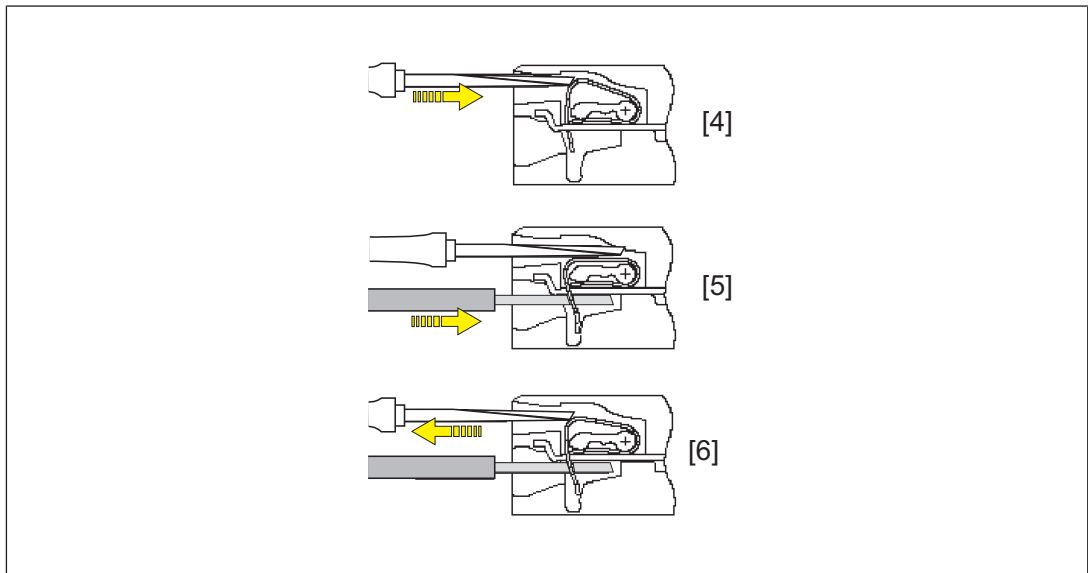
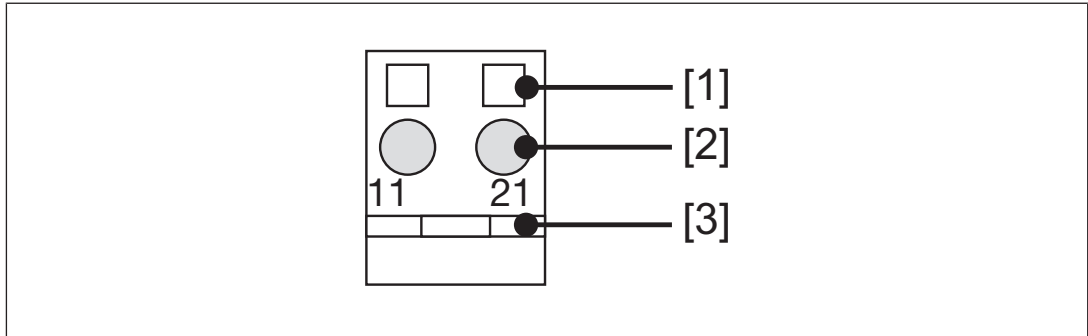

Please note:

- ▶ The minimum cable cross section for field connection terminals on the base modules is  $0.14 \text{ mm}^2$  (AWG26).
- ▶ The maximum cable cross section for field connection terminals is:
  - Digital inputs:  $1.5 \text{ mm}^2$  (AWG16)
  - Digital outputs:  $2.0 \text{ mm}^2$  (AWG14)
  - Inputs/outputs on the counter modules:  $1.5 \text{ mm}^2$  (AWG16)
  - Analogue inputs/outputs:  $1.5 \text{ mm}^2$  (AWG16)
  - Communication cables:  $1.5 \text{ mm}^2$  (AWG16)
  - Test pulse outputs:  $1.5 \text{ mm}^2$  (AWG16)
  - Power supply:  $2.5 \text{ mm}^2$  (AWG12)
  - Functional earth:  $2.5 \text{ mm}^2$  (AWG12)

- ▶ On base modules with screw terminals:
  - If you use a multi-strand cable to connect the I/Os, it is recommended that you use ferrules conforming to Parts 1 and 2 of DIN 46228, 0.14 ... 1.5 mm<sup>2</sup>, Form A or C, although this is not essential. To crimp the ferrules you can use crimp pliers (crimp form A or C) conforming to EN 60947-1, such as the PZ 1.5 or PZ 6.5 from Weidmüller, for example.
  - Maximum torque setting: 0.8 Nm
- ▶ Use copper wiring.

## 6.2 Terminal configuration

- ▶ Supply module
  - To refresh the periphery supply
  - To interrupt the incoming periphery supply and C-rail
  - To provide subsequent modules with the periphery supply and C-rail supply
  - To form supply groups

Base module	Terminal configuration	
Screw terminals: PSSu BS 1/8 S PSSu BS 1/8 S-T	11: Not connected  21: Not connected	
Cage clamp terminals: PSSu BS 1/8 C PSSu BS 1/8 C-T	12 -22: 0 V periphery supply, interrupted to the left (12-22 linked within the base module)	
	13 -23: +24 V periphery sup- ply, interrupted to the left (13-23 linked within the base module)	
	14-24 C-rail supply, interrupted to the left (14-24 linked within the base module)	

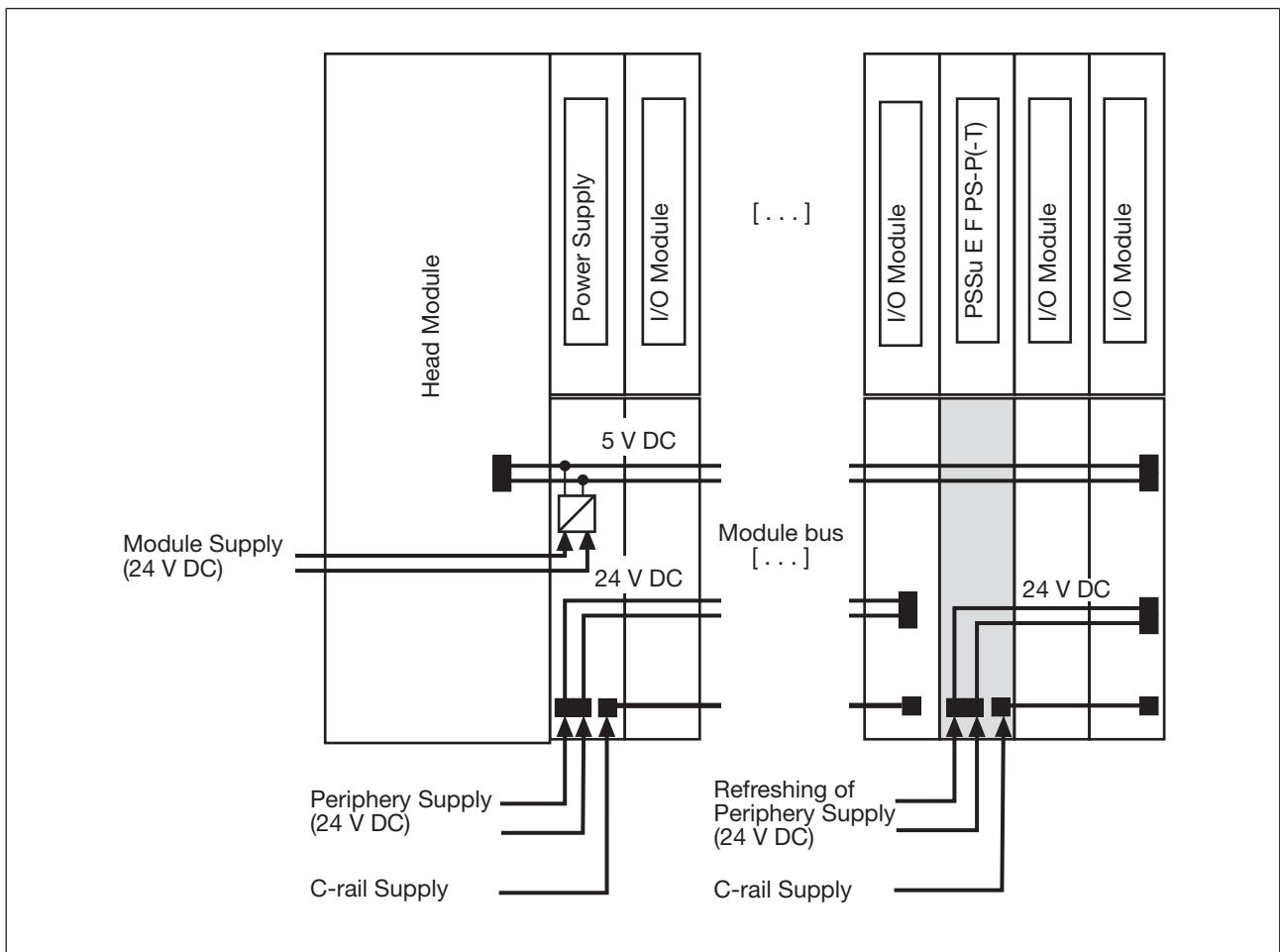

### 6.3 Connecting the module

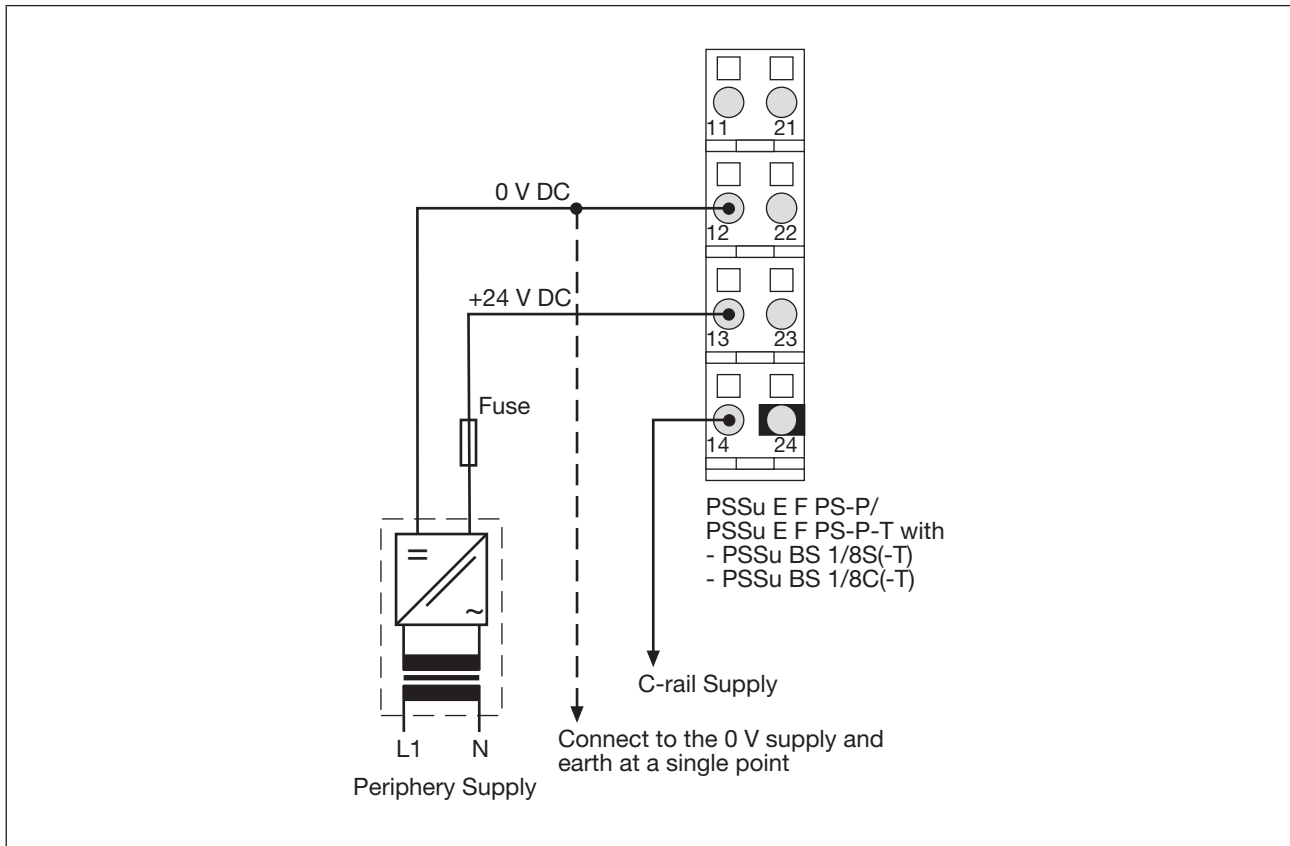

## 7 Operation

### 7.1 Messages

A module error is displayed via the “Err” LED (see section entitled “Display elements”), signalled to the head module and then entered in the head module's error stack or diagnostic log.



The module can detect the following errors:

Module error	Explanation	Remedy
Start-up error	Error as the PSSu system starts up	Change faulty module.
Configuration error	Incorrect module type configured.	The configured hardware registry does not match the actual hardware registry.
FS communication error	Error during FS communication	Change faulty module.
Temperature error: too warm	Ambient temperature too high: Entry in the error stack or diagnostic log	Ensure there is sufficient ventilation in the control cabinet or prevent overload.
Overvoltage error	A system voltage or infeed is too high.	Stabilise the supply or change the faulty supply voltage module.
Undervoltage error	A system voltage or infeed is too low.	Stabilise the supply or change the faulty supply voltage module.
Error in the overvoltage protection diodes	Overvoltage protection diodes are defective.	Change faulty supply voltage module.

Further information on PSSu error messages is available in the online help for PSS WIN-PRO or PAS4000.



### 7.2 Display elements

#### Legend

-  LED on
-  LED off

#### 7.2.1 Anzeigeelemente zur Moduldiagnose

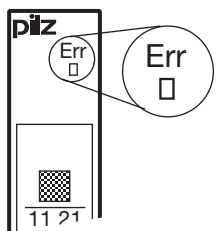
The module has an LED for displaying module errors ("Err" LED).

	LED			Meaning
	Name	Colour	Status	
	Err	---		No error
	Red		Module error	

### 7.2.2 Display elements for the status of the periphery supply

A status LED is assigned to the periphery supply ("24 V" LED).

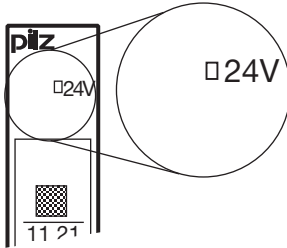
	LED			Key
	Description	Colour	Status	
	24 V	---	●	No supply voltage or error in the supply voltage for periphery supply
	green	☀	Supply voltage for periphery supply is error-free	

## 8 Technical details

<b>General</b>	<b>312185</b>	<b>314185</b>	<b>315185</b>
Approvals	<b>CE, EAC (Eurasian), KOSHA, TÜV, cULus Listed</b>	<b>CE, EAC (Eurasian), KOSHA, TÜV, cULus Listed</b>	<b>CE, TÜV</b>
Application range	<b>Standard/failsafe</b>	<b>Standard/failsafe</b>	<b>Standard/failsafe</b>
Module's device code	<b>0802h</b>	<b>0802h</b>	<b>0802h</b>
Application in system environment A			
From FS firmware version, other head modules	<b>4</b>	<b>4</b>	–
From ST firmware version, other head modules	<b>5</b>	<b>5</b>	–
From FS firmware version PSSu H F PN	<b>1</b>	<b>1</b>	–
From ST firmware version PSSu H S PN	<b>1</b>	<b>1</b>	–
From ST firmware version PSSu WR S IDN	<b>6</b>	<b>6</b>	–
Application in system environment B			
From FS firmware version, head modules	<b>1.0.0</b>	<b>1.0.0</b>	<b>1.5.0</b>
From ST firmware version, head modules	<b>1.0.0</b>	<b>1.0.0</b>	<b>1.0.0</b>
<b>Electrical data</b>	<b>312185</b>	<b>314185</b>	<b>315185</b>
Supply voltage			
for	<b>Periphery supply</b>	<b>Periphery supply</b>	<b>Periphery supply</b>
Voltage	<b>24 V</b>	<b>24 V</b>	<b>24 V</b>
Kind	<b>DC</b>	<b>DC</b>	<b>DC</b>
Voltage tolerance	<b>-30 %/+25 %</b>	<b>-30 %/+25 %</b>	<b>-30 %/+25 %</b>
Current load capacity at UB	<b>10 A</b>	<b>10 A</b>	<b>10 A</b>
Rated surge voltage	<b>3050 V</b>	<b>3050 V</b>	–
Internal supply voltage (module supply)			
Module's power consumption	<b>0,12 W</b>	<b>0,12 W</b>	<b>0,12 W</b>
Potential isolation	<b>3050 V</b>	<b>3050 V</b>	<b>3050 V</b>
Periphery's supply voltage (periphery supply)			
Module's current consumption with no load	<b>5 mA</b>	<b>5 mA</b>	<b>5 mA</b>
Module's power consumption with no load	<b>0,12 W</b>	<b>0,12 W</b>	<b>0,12 W</b>
Max. power dissipation of module	<b>0,5 W</b>	<b>0,5 W</b>	<b>0,5 W</b>

<b>Environmental data</b>	<b>312185</b>	<b>314185</b>	<b>315185</b>
<b>Application site</b>			
In accordance with the standard	–	–	EN 50125-3
Application site	–	–	Track area (1 m - 3 m)
In accordance with the standard	–	–	EN 61373
Application site	–	–	Category 1, Class A + B
<b>Climatic suitability</b>	<b>EN 60068-2-1, EN 60068-2-14, EN 60068-2-2, EN 60068-2-30, EN 60068-2-78</b>	<b>EN 60068-2-1, EN 60068-2-14, EN 60068-2-2, EN 60068-2-30, EN 60068-2-78</b>	<b>EN 50125-1, EN 50125-3, EN 50155, EN 60068-2-1, EN 60068-2-14, EN 60068-2-2</b>
<b>Ambient temperature</b>			
In accordance with the standard	–	–	EN 50155
Temperature range	<b>0 - 60 °C</b>	<b>-40 - 70 °C</b>	<b>-40 - 70 °C</b>
Max. temperature in accordance with UL	–	<b>0 ... 60 °C</b>	–
In accordance with the standard	–	–	EN 50125-1
Temperature range	–	–	<b>-40 ... +70 °C</b>
In accordance with the standard	–	–	EN 50125-3
Temperature range	–	–	<b>-40 ... +70 °C</b>
<b>Storage temperature</b>			
Temperature range	<b>-25 - 70 °C</b>	<b>-40 - 70 °C</b>	–
<b>Climatic suitability</b>			
In accordance with the standard	<b>EN 60068-2-30, EN 60068-2-78</b>	<b>EN 60068-2-30, EN 60068-2-78</b>	–
Humidity	<b>93 % r. h. at 40 °C</b>	<b>93 % r. h. at 40 °C</b>	–
<b>Condensation during operation</b>			
	<b>Not permitted</b>	<b>Short-term</b>	–
<b>Max. operating height above sea level</b>			
	<b>2000 m</b>	<b>5000 m</b>	<b>2000 m</b>
<b>EMC</b>			
	<b>EN 61000-4-2, EN 61000-4-3, EN 61000-4-4, EN 61000-4-5, EN 61000-4-6, EN 61000-6-2, EN 61000-6-4</b>	<b>EN 61000-4-2, EN 61000-4-3, EN 61000-4-4, EN 61000-4-5, EN 61000-4-6, EN 61000-6-2, EN 61000-6-4</b>	<b>EN 61000-4-2, EN 61000-4-3, EN 61000-4-4, EN 61000-4-5, EN 61000-4-6, EN 61000-6-2, EN 61000-6-4</b>
<b>Vibration</b>			
In accordance with the standard	<b>EN 60068-2-6</b>	<b>EN 60068-2-6</b>	<b>EN 50125-3</b>
Frequency	<b>10 - 150 Hz</b>	<b>10 - 1000 Hz</b>	<b>5 - 2000 Hz</b>
Amplitude	<b>0,35 mm</b>	<b>0,35 mm</b>	–
Acceleration	<b>1g</b>	<b>5g</b>	<b>0,23g</b>

<b>Environmental data</b>	<b>312185</b>	<b>314185</b>	<b>315185</b>
<b>Broadband noise</b>			
In accordance with the standard	–	EN 60068-2-64	EN 61373
Frequency	–	5 - 500 Hz	5 - 150 Hz
Acceleration	–	1,9grms	0,79 g RMS
<b>Shock stress</b>			
In accordance with the standard	EN 60068-2-27	EN 60068-2-27	EN 50125-3
Number of shocks	6	6	20
Acceleration	15g	15g	2g
Duration	11 ms	11 ms	11 ms
In accordance with the standard	EN 60068-2-27	EN 60068-2-27	EN 61373
Number of shocks	1000	1000	20
Acceleration	10g	25g	5g
Duration	16 ms	6 ms	30 ms
<b>Supply interruptions</b>			
In accordance with the standard	–	–	EN 50155
Class	–	–	S2, C1, C2
<b>Airgap creepage</b>			
In accordance with the standard	EN 60664-1	EN 60664-1	EN 50124-1
Overvoltage category	II	II	OV2
Pollution degree	2	2	PD2
<b>Protection type</b>			
In accordance with the standard	EN 60529	EN 60529	EN 60529
Housing	IP20	IP20	IP20
Terminals	IP20	IP20	–
Mounting area (e.g. control cabinet)	IP54	IP54	IP51
<b>Mechanical data</b>	<b>312185</b>	<b>314185</b>	<b>315185</b>
<b>Material</b>			
Bottom	PC	PC	PC
Front	PC	PC	PC
Coding	PA	PA	PA
Mounting type	plug-in	plug-in	plug-in
<b>Dimensions</b>			
Height	76 mm	76 mm	76 mm
Width	12,6 mm	12,6 mm	12,6 mm
Depth	60,2 mm	60,2 mm	60,2 mm
Weight	33 g	34 g	35 g
<b>Mechanical coding</b>			
Type	A	A	A
Colour	Yellow	Yellow	Yellow

Where standards are undated, the 2015-03 latest editions shall apply.

## 9 Order reference

### 9.1 Product

Product type	Features	Order No.
PSSu E F PS-P	Electronic module, base type	312 185
PSSu E F PS-P-T	Electronic module, T-type	314 185
PSSu E F PS-P-R	Electronic module, R-type	315 185

### 9.2 Accessories

#### Base modules

Product type	Features	Order No.
PSSu BS 1/8 S	Base module with screw terminals, for use only as the first module after the head module	312 650
PSSu BS 1/8 S-T	Base module with screw terminals, for use only as the first module after the head module, T-type	314 650
PSSu BS 1/8 C	Base module with cage clamp terminals, for use only as the first module after the head module	312 651
PSSu BS 1/8 C-T	Base module with cage clamp terminals, for use only as the first module after the head module, T-type	314 651